



# PETER BOND

& Associates (Pty) Ltd.

Co No. 2012/003986/07

Civil & Structural Engineers, Architecture &  
Quantity Surveying

OFFICES 31 & 32  
KYALAMI ON MAIN SHOPPING CENTRE  
DYTCHLEY / MAIN (R55) ROADS  
BARBEQUE DOWNS, KYALAMI  
MIDRAND

P.O. BOX 30611  
KYALAMI  
1684

TEL: 011 466 0364  
E MAIL: [gp@peterbond.co.za](mailto:gp@peterbond.co.za)  
WEB: [www.peterbond.co.za](http://www.peterbond.co.za)

FAX: 011 466 1644  
E mail fax: 086 581 5322  
CELL: 082 4434943

F553/11/6824 KDS-IBR78-PCSLOT

20 October 2023

## **PANEL SUPPORT BRACKET: KDS- IBR78-PCSLOT**

The KDS-IBR78-PCSLOT is a fixing bracket designed for securing the support frame for solar panels to a roof truss where the roof covering is IBR sheeting. When installed in accordance with the KDS installation guide for framed panels and secured with 6 x 6mm diameter TEK screws, the KDS-IBR78-PCSLOT will provide anchoring of the panel frame to the roof sheets.

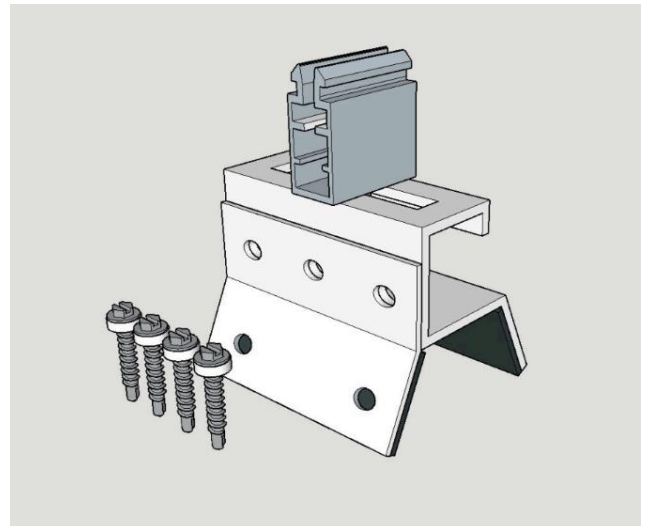

The assumptions in calculating the pull out force required to be withstood by the bracket are:-

- Solar panel size 2 x 1.2m anchored by 2 KDS-IBR78 PCSLOT Brackets per panel
- Wind loads calculated in accordance with SANS 0160: The general procedures and loadings to be adopted in the design of buildings with the following parameters.
- The worst case wind loads were considered, these being

Terrain category 1 (Flat smooth terrain, sea coast, lake shores of flat plains)

Maximum regional wind speed for South Africa

A return period of 1 in 50 years.

Density of air at sea level

The wind loads were calculated using the formulas  $q_z = k_p V^2$  and  $p_z = C_p q_z$

Where  $q$  is free stream velocity pressure

$K_p$  is a constant dependent on altitude

$V$  is characteristic wind speed

$C_p$  is pressure coefficient for the particular part or surface of the building

$p_z$  pressure on the surface of the building

A value of  $C_p = 1$  was taken as covering a worst case for the multitude of permutations possible in determining this coefficient.

Wind loads at the edges of roofs localized high wind loads. The installation guide limits the placement of solar panels to the areas indicated in the below layout diagrams.

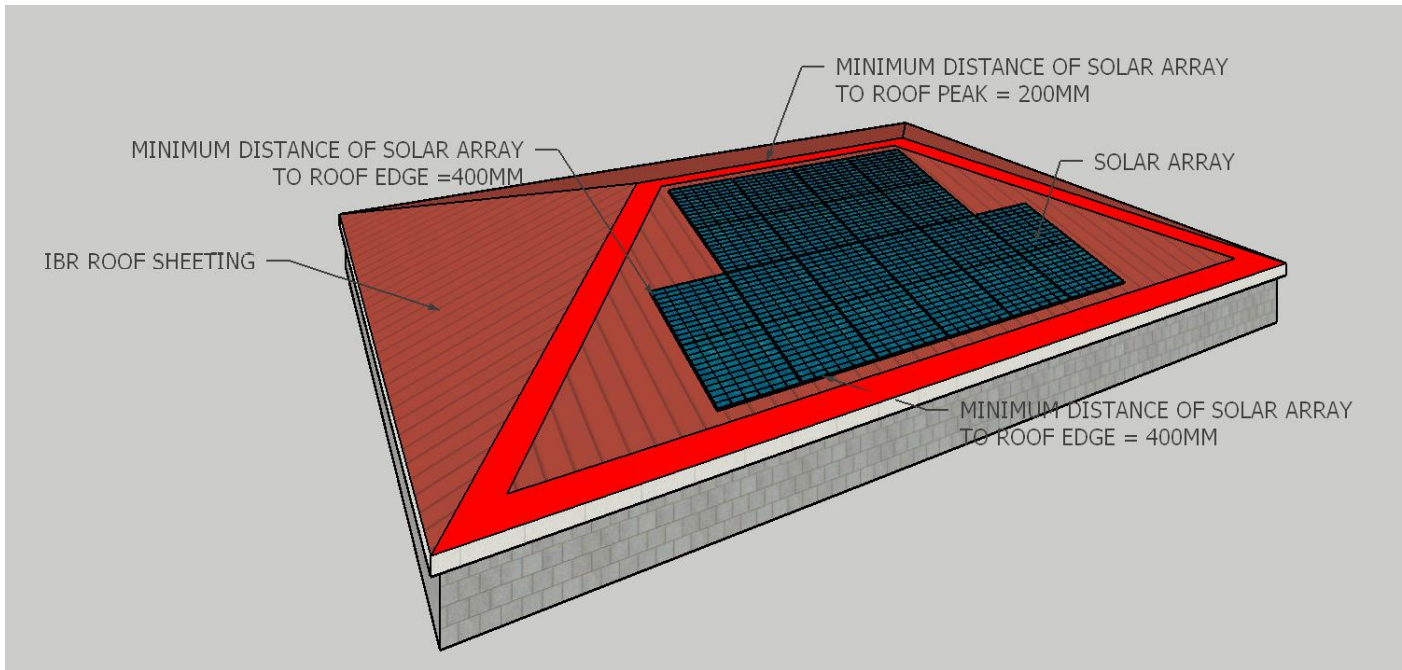

**Graeme Parker**  
**PETER BOND & ASSOCIATES (PTY) LTD**  
*Pr Eng. 20160449*